



VERTICAL PLATFORM LIFTS

Design Guide

VPC-UL (Unenclosed Lift)

VPC-SL (Shaftway Lift)

VPC-EL (Enclosure Lift)

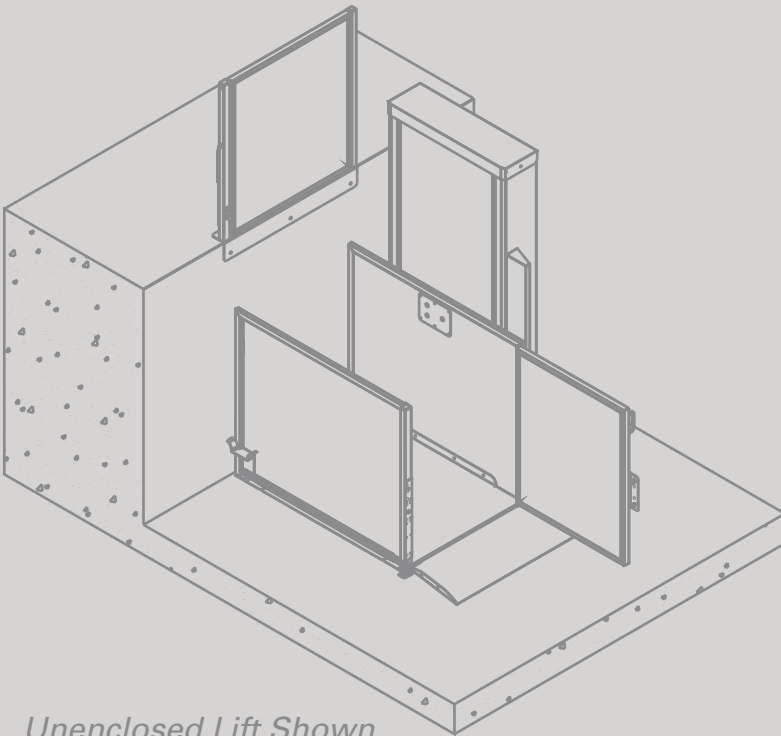

Unenclosed Lift Shown

www.SymmetryElevator.com

Symmetry VPC

Vertical Platform Lifts

Table of Contents

Company Introduction	3
General Rules for VPC Applications	4
Component Identification	5
Hoistway Layouts	6
Main Tower Height Information	13
Reaction Forces	14
Gates & Doors	15
Pits and Ramps	18
Controls	19
Construction Notes	20
Conduit Layout	21
Typical Specifications	22

About Symmetry

We've taken decades of customer feedback and turned that knowledge into the Symmetry *Vertical Platform Conveyance* (VPC), our designation for the industry's *Vertical Platform Lift* (VPL). It is a unique mobility product from people who understand that multiple floors don't have to be an obstacle.

Symmetry's philosophy is "more space for living." That's why we designed platform lifts that take up less room and seamlessly fit into any style of home or commercial application. Even when they blend in, Symmetry platform lifts stand out with simple operation, reliable function, and options that are virtually limitless.

Commercial or Home Installation

An unenclosed vertical lift requires little or no site modifications and is an ideal accessibility solution when space and costs are the primary concerns. They are commonly used in public facilities when the travel does not exceed 60" and private residences at travel heights up to 144". An enclosed vertical lift requires slightly more space and is used in public and private facilities at travel heights up to 144". A shaftway vertical lift is designed for enclosed shaftway applications, including floor penetration, in public and private facilities at travel heights up to 144".

Meets ADA Requirements

Vertical lifts are approved in the ADA Accessibility Guidelines as a means to provide unassisted entry and exit from buildings, service or recreational facilities. Built in accordance with ASME A18.1. Check with your local Symmetry provider to determine if additional State or local approvals or travel height restrictions are required.

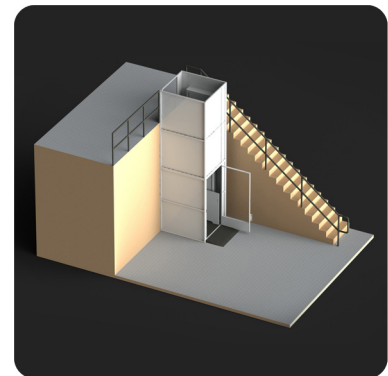
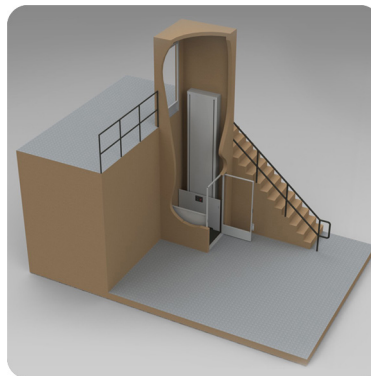
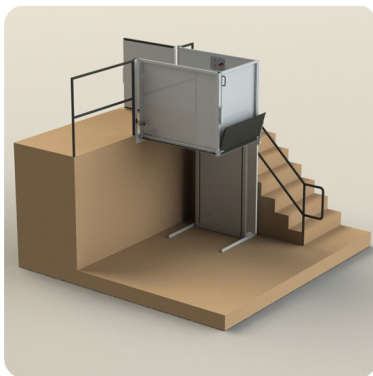
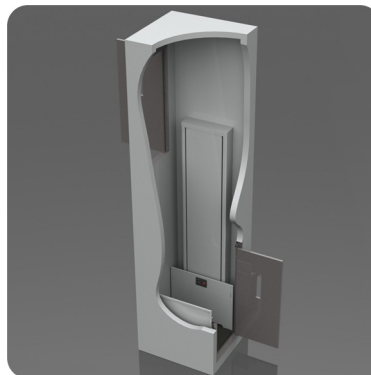
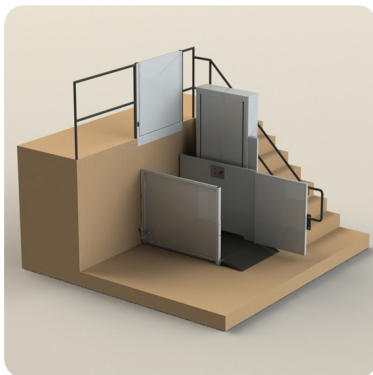

VPC-UL
(Unenclosed Lift)

VPC-SL
(Shaftway Lift)

VPC-EL
(Enclosure Lift)

General Rules for VPC Applications:

These rules have been developed as a guideline and are based on the information supplied in ANSI A117.1-2009 and ASME A18.1-2008. Please consult your local authority having jurisdiction regarding local codes and regulations.

PLATFORMS:

- 30" x 48" minimum clear space on platform for most applications.
- If the VPC exits 90 degrees from an entry point the clear space must be 42" x 60".

DOORS AND GATES:

- 32" minimum clear opening for a door or gate accessing the VPC from the end.
- 42" minimum clear opening for a door or gate accessing the VPC from the side.
- All doors/ gates require a minimum 18" latch side clearance. A greater distance may need to be provided as described in ANSI A117.1-2009.
- Power assisted doors/gates are required in all applications that are not straight through. This includes all applications servicing more than 2 landings.
- Gates must be a minimum 42" tall.
- Doors must have 80" clear inside height.
- Doors/gates must be installed flush to the interior of the hoistway.
- In unenclosed commercial applications a traveling gate mounted to the platform, in conjunction with a safety pan (*under platform safety device*), is required.
- In unenclosed residential applications less than 60" in travel height an automatic folding ramp may be used in lieu of a platform gate.

LIFT HEIGHT:

- Unenclosed commercial applications cannot exceed 60" in travel height.
- Unenclosed residential applications are available at travel heights not to exceed 168".
- Shaftway and enclosure applications, both commercial and residential, are available at travel heights not to exceed 168".
- Some State and local jurisdictions have additional travel height restrictions.

RAMPS:

- Stationary end ramps will project 25" from either the edge of the running clearance (*for models with a platform gate*) or the outside face of the lower landing door or gate.
- Automatic folding ramps will project 15" from the edge of the platform on the lower landing side of the lift.
- Stationary side ramps will project a minimum of 25" from the outside face of the lower landing door or gate.

PITS:

- The minimum depth of a pit for a VPC will be 2 1/2". A 3" pit is recommended.
- When a VPC is installed in a pit and in an outdoor application the pit must have a drain.

ANCHORING:

- The machine tower must be anchored to a wall, unless the travel height is less than 60".
- The machine base must be anchored to the floor.
- Doors and gates are not free-standing and must be anchored vertically and horizontally.

RUNNING CLEARANCES:

- The running clearance on a side of the lift that will be used to enter/exit the lift must be 3/8" minimum to 3/4" maximum.
- The running clearance on a non-opening side of the platform must be 2" minimum.

COMPONENT IDENTIFICATION

Straight Through Configuration Unenclosed Unit

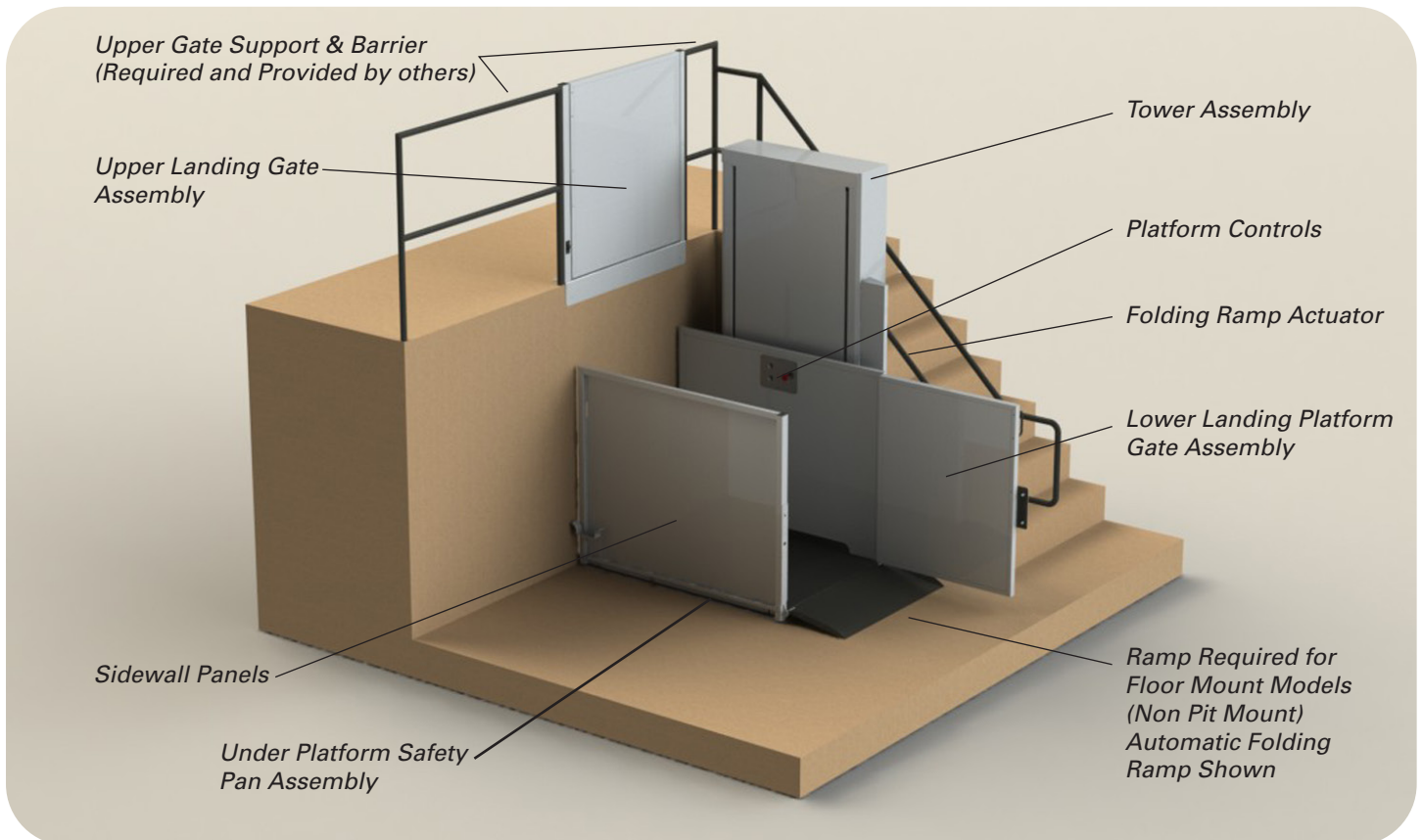

View from behind machine tower with rear cover removed.

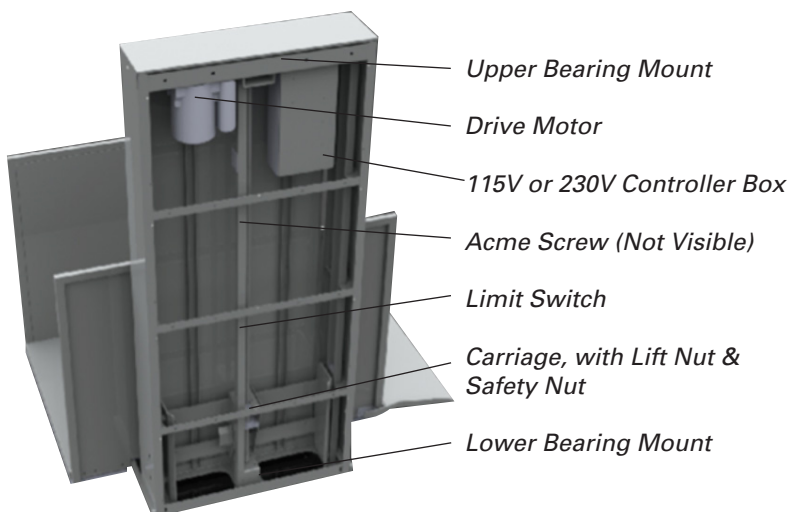

LED Diagnostic Board
(located under main tower cap)

UNENCLOSED DESIGN - STRAIGHT THROUGH

Lower Landing Pit Mount, Stationary Ramp, & Flip Up Ramp Applications shown.

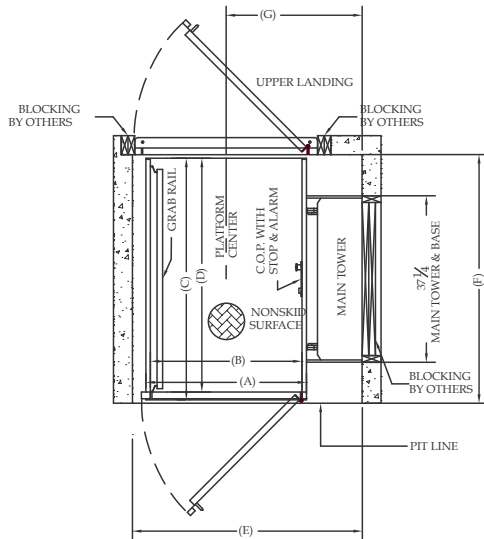

LOWER LANDING PIT MOUNTED APPLICATION SHOWN

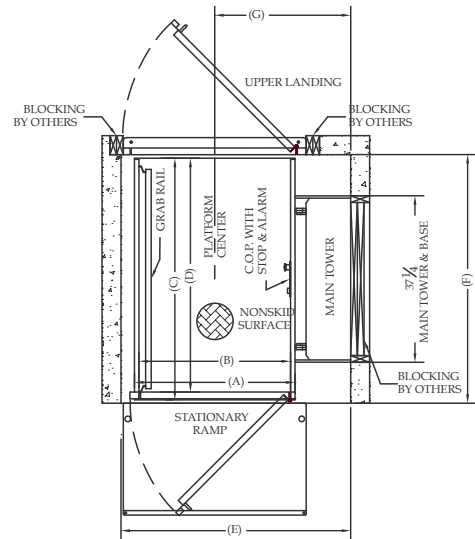

LOWER LANDING STATIONARY RAMP APPLICATION SHOWN

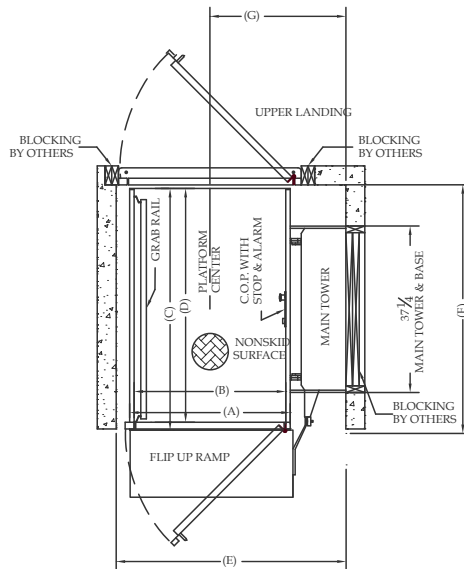

LOWER LANDING FLIP UP RAMP APPLICATION SHOWN

STRAIGHT THROUGH						
PLATFORM WIDTH (A)	CLEAR PLATFORM WIDTH (B)	PLATFORM LENGTH (C)	CLEAR PLATFORM LENGTH (D)	FINISHED HOISTWAY WIDTH (E)	FINISHED HOISTWAY LENGTH (F)	UPPER CENTER LINE (G)
36"	34"	54"	52 1/4"	51 1/2 "	55 1/2 "	30 1/2 "
36"	34"	60"	58 1/4"	51 1/2 "	61 1/2 "	30 1/2 "
42"	40"	60"	58 1/4"	57 1/2 "	61 1/2 "	33 1/2 "

SHAFTWAY DESIGN - STRAIGHT THROUGH

Lower Landing Pit Mounted & Stationary Ramp Applications shown.

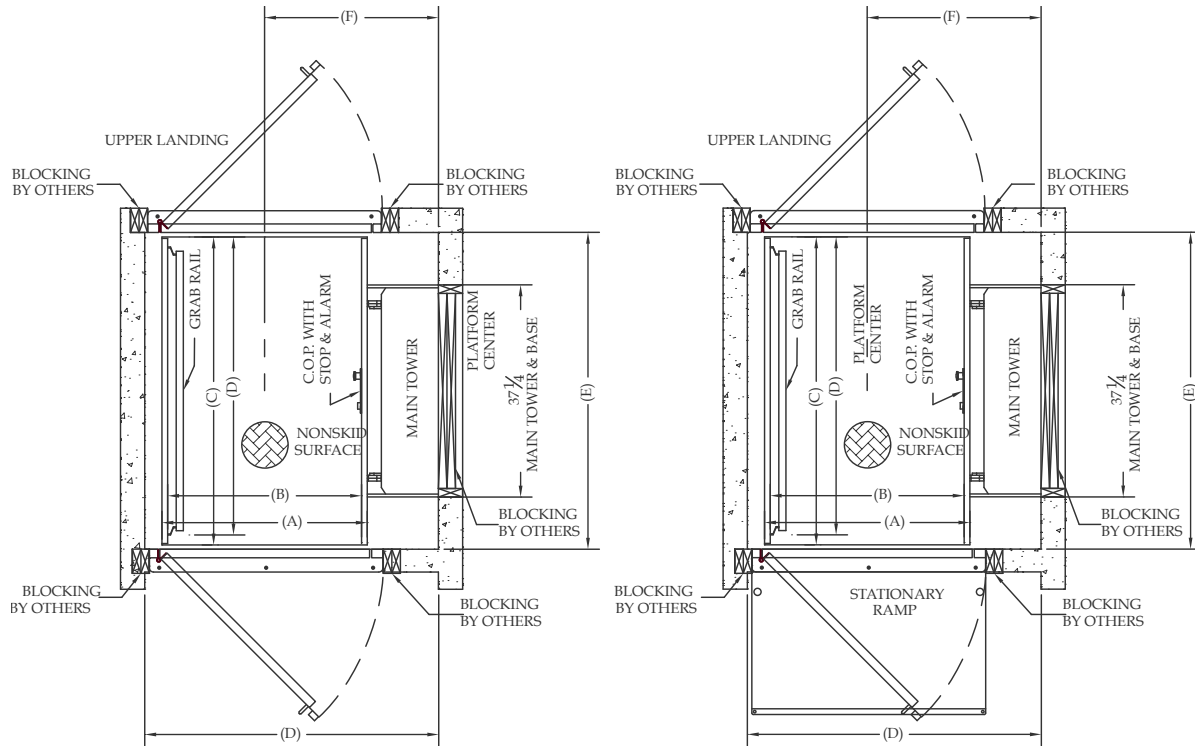

LOWER LANDING PIT MOUNTED APPLICATION SHOWN

LOWER LANDING STATIONARY RAMP APPLICATION SHOWN

STRAIGHT THROUGH					
PLATFORM WIDTH (A)	CLEAR PLATFORM WIDTH (B)	PLATFORM LENGTH (C)	FINISHED HOISTWAY WIDTH (D)	FINISHED HOISTWAY LENGTH (E)	UPPER CENTER LINE (F)
36"	34"	48"	51 ½ "	49 ½ "	30 ½ "
36"	34"	54"	51 ½ "	55 ½ "	30 ½ "
36"	34"	60"	51 ½ "	61 ½ "	30 ½ "
42"	40"	60"	57 ½ "	61 ½ "	33 ½ "

SHAFTWAY DESIGN - ENTER/EXIT SAME SIDE

Lower Landing Pit Mount & Stationary Ramp Applications shown.

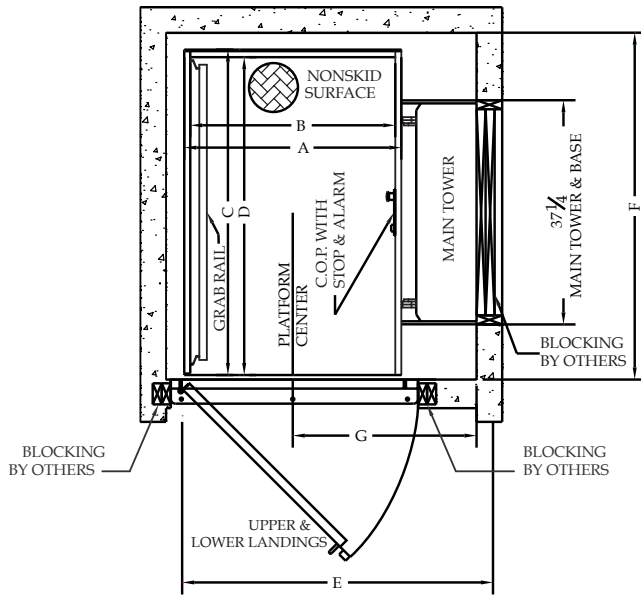

LOWER LANDING PIT MOUNTED APPLICATION SHOWN

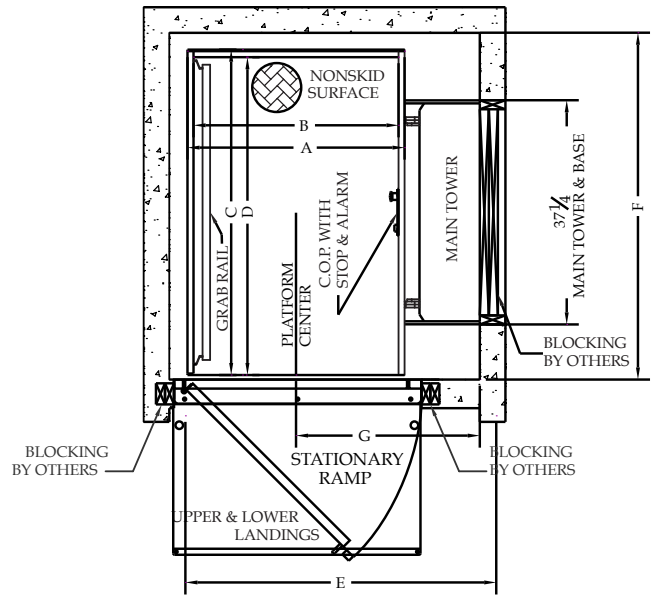

LOWER LANDING STATIONARY RAMP APPLICATION SHOWN

ENTER/EXIT SAME SIDE						
PLATFORM WIDTH (A)	CLEAR PLATFORM WIDTH (B)	PLATFORM LENGTH (C)	CLEAR PLATFORM LENGTH (D)	FINISHED HOISTWAY WIDTH (E)	FINISHED HOISTWAY LENGTH (F)	PLATFORM CENTER LINE (G)
36"	34"	54"	52 3/4"	51 1/2 "	57 1/2 "	30 1/2 "
36"	34"	60"	58 3/4"	51 1/2 "	63 1/2 "	30 1/2 "
42"	40"	60"	58 3/4"	57 1/2 "	63 1/2 "	33 1/2 "

SHAFTWAY DESIGN - 90 DEGREE EXIT

Lower Landing Pit Mounted & Stationary Ramp Applications shown.

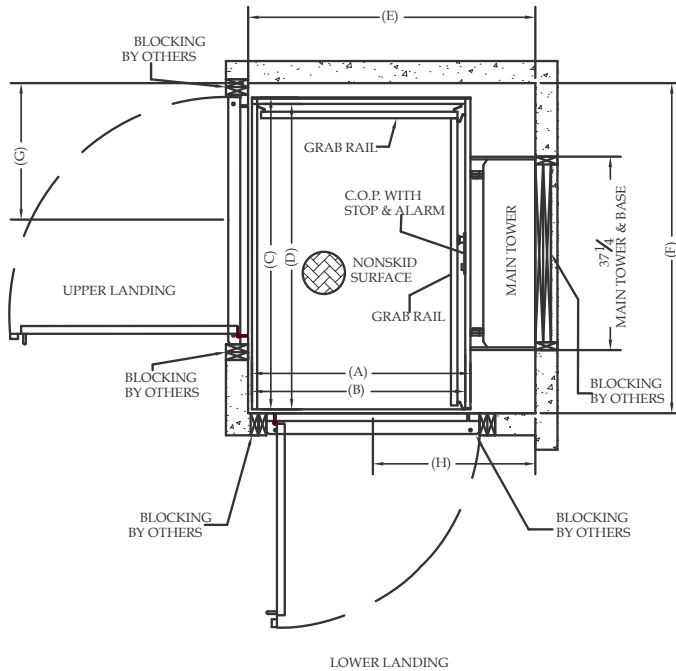

LOWER LANDING PIT MOUNTED APPLICATION SHOWN

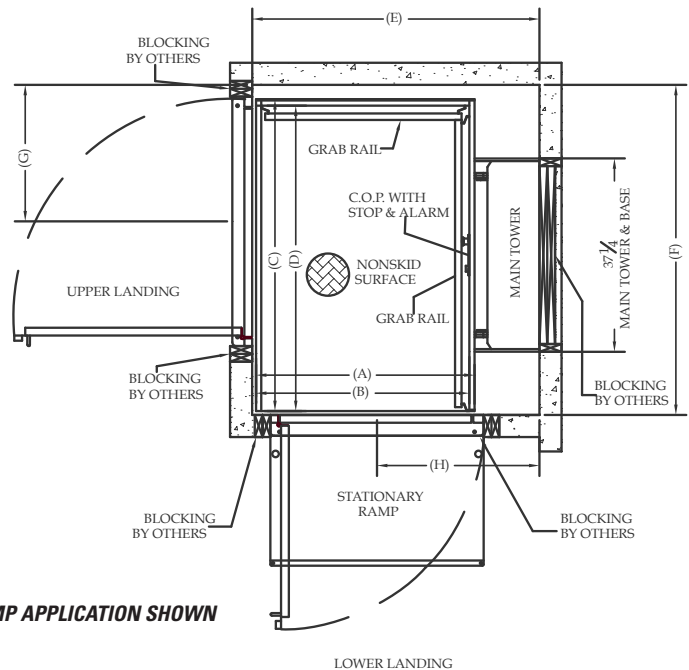

LOWER LANDING STATIONARY RAMP APPLICATION SHOWN

90° EXIT							
PLATFORM WIDTH (A)	CLEAR PLATFORM WIDTH (B)	PLATFORM LENGTH (C)	CLEAR PLATFORM LENGTH (D)	FINISHED HOISTWAY WIDTH (E)	FINISHED HOISTWAY LENGTH (F)	UPPER CENTER LINE (G)	LOWER GATE CENTER LINE (H)
42"	41"	60"	58 ³ / ₄ "	55 ¹ / ₄ "	63 ¹ / ₂ "	26 ¹ / ₄ "	31 ¹ / ₄ "

ENCLOSURE DESIGN - STRAIGHT - THROUGH

Lower Landing Pit Mount & Stationary Ramp Applications shown.

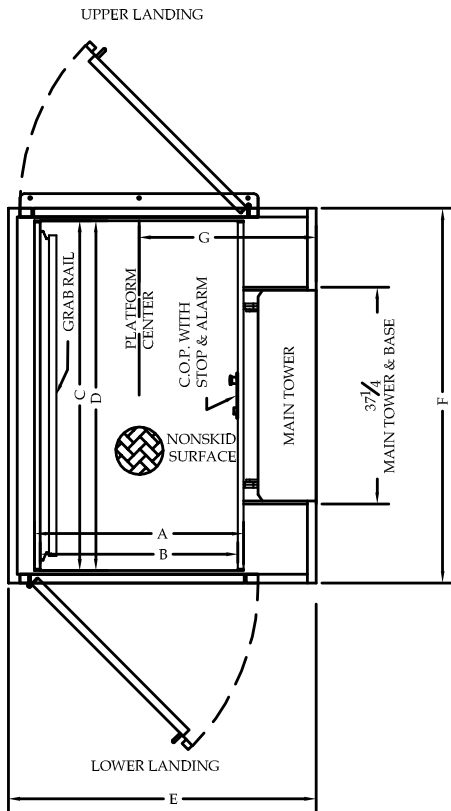

LOWER LANDING PIT MOUNTED APPLICATION SHOWN

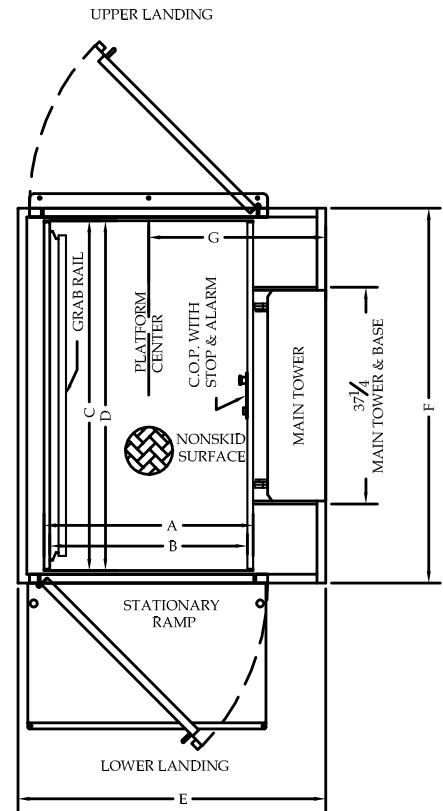

LOWER LANDING STATIONARY RAMP APPLICATION SHOWN

STRAIGHT THROUGH						
PLATFORM WIDTH (A)	CLEAR PLATFORM WIDTH (B)	PLATFORM LENGTH (C)	CLEAR PLATFORM LENGTH (D)	FINISHED ENCLOSURE WIDTH (E)	FINISHED ENCLOSURE LENGTH (F)	PLATFORM CENTER LINE (G)
36"	34"	48"	48"	53"	52½"	30"
36"	34"	54"	54"	53"	58½"	30½"
36"	34"	60"	60"	53"	64½"	30½"
42"	40"	60"	60"	59"	64½"	33½"

NOTE: FOR PIT DIMENSIONS, ADD 3/4" TO THE ENCLOSURE DIMENSIONS, IN EACH DIRECTION.

ENCLOSURE DESIGN - ENTER/EXIT SAME SIDE

Lower Landing Pit Mount & Stationary Ramp Applications shown.

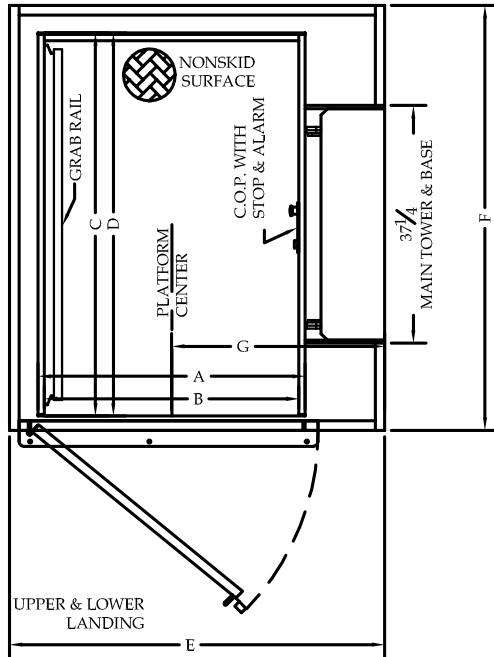

LOWER LANDING PIT MOUNTED APPLICATION SHOWN

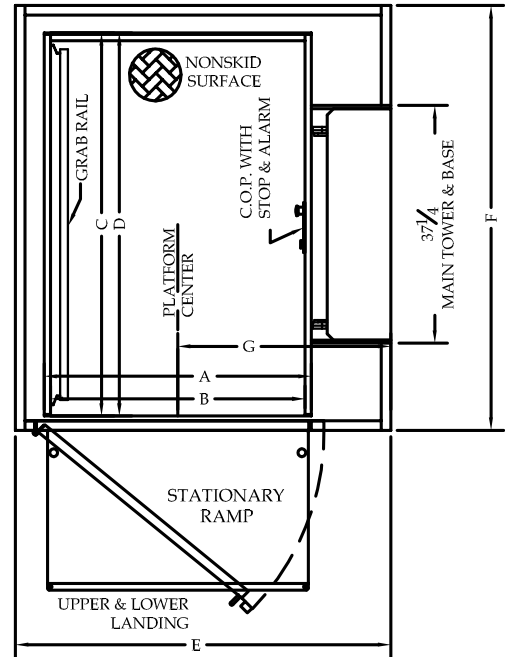

LOWER LANDING STATIONARY RAMP APPLICATION SHOWN

ENTER/EXIT SAME SIDE						
PLATFORM WIDTH (A)	CLEAR PLATFORM WIDTH (B)	PLATFORM LENGTH (C)	CLEAR PLATFORM LENGTH (D)	FINISHED ENCLOSURE WIDTH (E)	FINISHED ENCLOSURE LENGTH (F)	PLATFORM CENTER LINE (G)
36"	34"	54"	52 3/4"	53"	60 1/2"	30 1/2"
36"	34"	60"	58 3/4"	53"	66 1/2"	30 1/2"
42"	40"	60"	58 3/4"	59"	66 1/2"	33 1/2"

NOTE: FOR PIT DIMENSIONS, ADD 3/4" TO THE ENCLOSURE DIMENSIONS, IN EACH DIRECTION.

ENCLOSURE DESIGN - 90 DEGREE EXIT

Lower Landing Pit Mount & Stationary Ramp Applications shown.

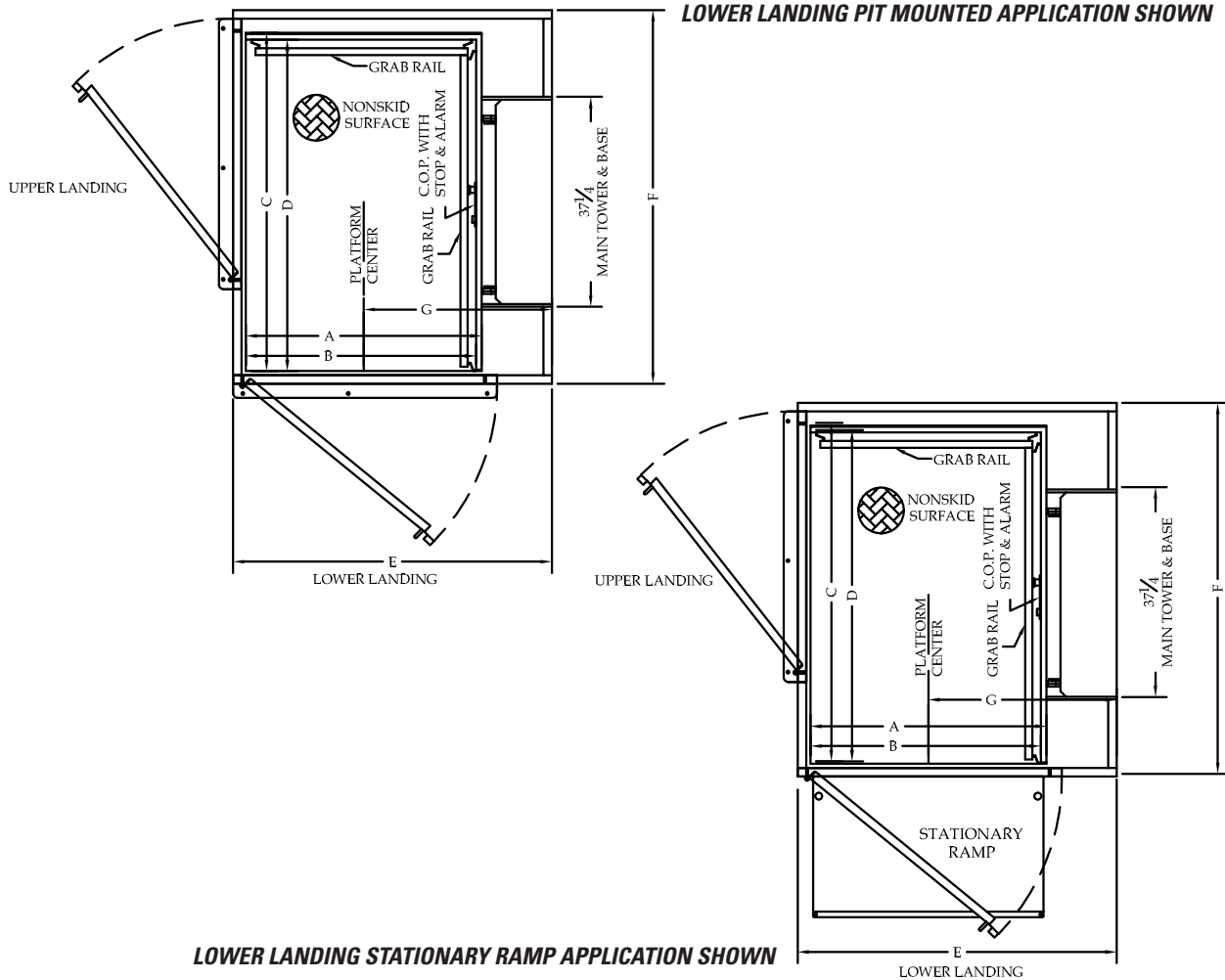

90° EXIT						
PLATFORM WIDTH (A)	CLEAR PLATFORM WIDTH (B)	PLATFORM LENGTH (C)	CLEAR PLATFORM LENGTH (D)	FINISHED ENCLOSURE WIDTH (E)	FINISHED ENCLOSURE LENGTH (F)	PLATFORM CENTER LINE (G)
42"	41"	60"	58 ³ / ₄ "	56 ³ / ₄ "	66 ¹ / ₂ "	33 ¹ / ₂ "

NOTE: FOR PIT DIMENSIONS, ADD 3/4" TO THE ENCLOSURE DIMENSIONS, IN EACH DIRECTION.

MAIN TOWER HEIGHT INFORMATION

STATIONARY RAMP APPLICATION

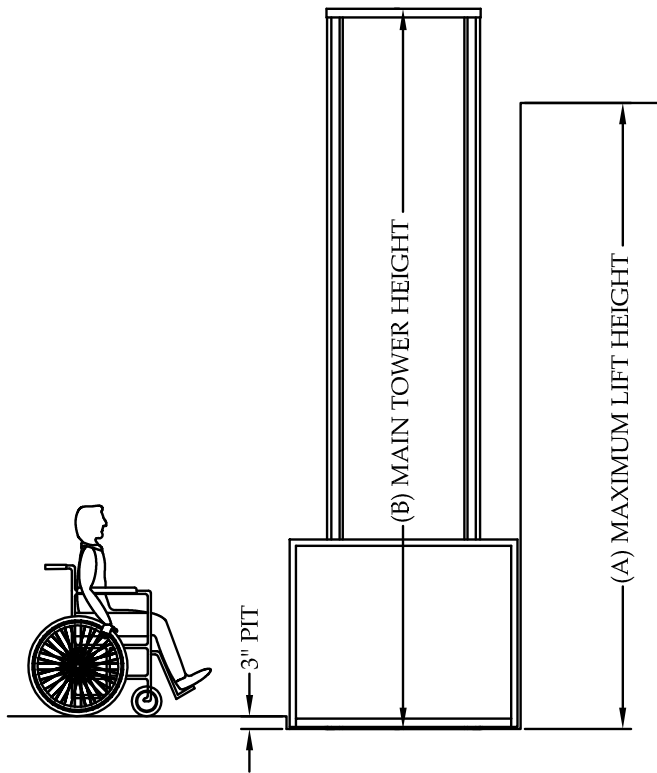

PITTED APPLICATION

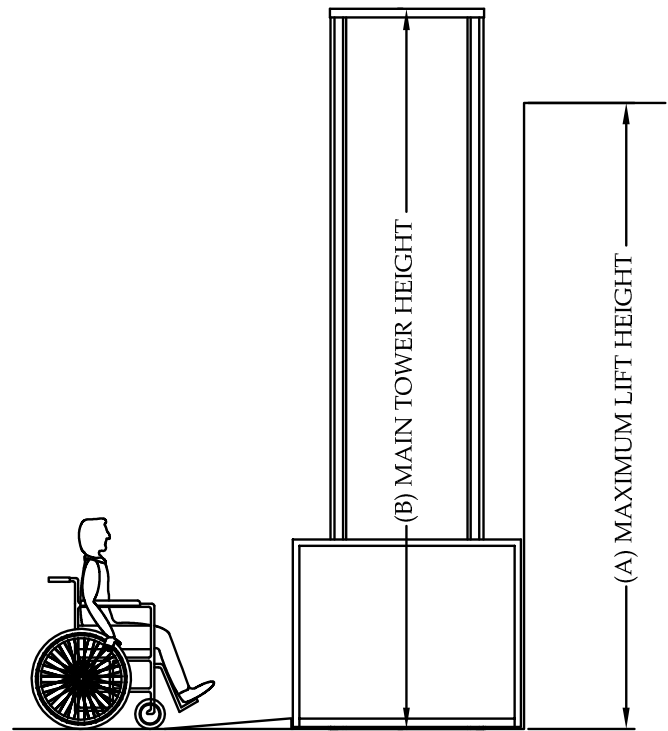

MAIN TOWER INFORMATION		
MODEL DESIGNATION	(A) MAXIMUM TRAVEL	(B) TOWER HEIGHT
60	63"	85 $\frac{1}{8}$ "
96	99"	121"
120	123"	145"
144	147"	169"
168	171"	193"

REACTION FORCES

*** ALL LOADS ASSUME A MAXIMUM SIZED PLATFORM COMPLETE WITH PLATFORM GATE, FLIP UP RAMP, & SAFETY PAN**

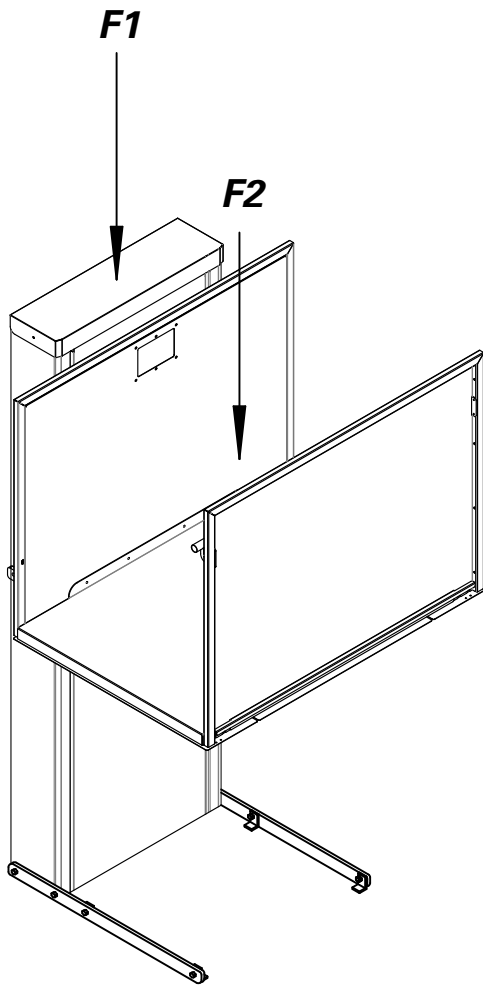

$F1 = \text{TOWER WEIGHT} = 450 \text{ lbf}$

**$F2 = \text{PLATFORM WEIGHT} + \text{CAPACITY}$
 $= 400 \text{ lbf} + 750 \text{ lbf} = 1150 \text{ lbf}$**

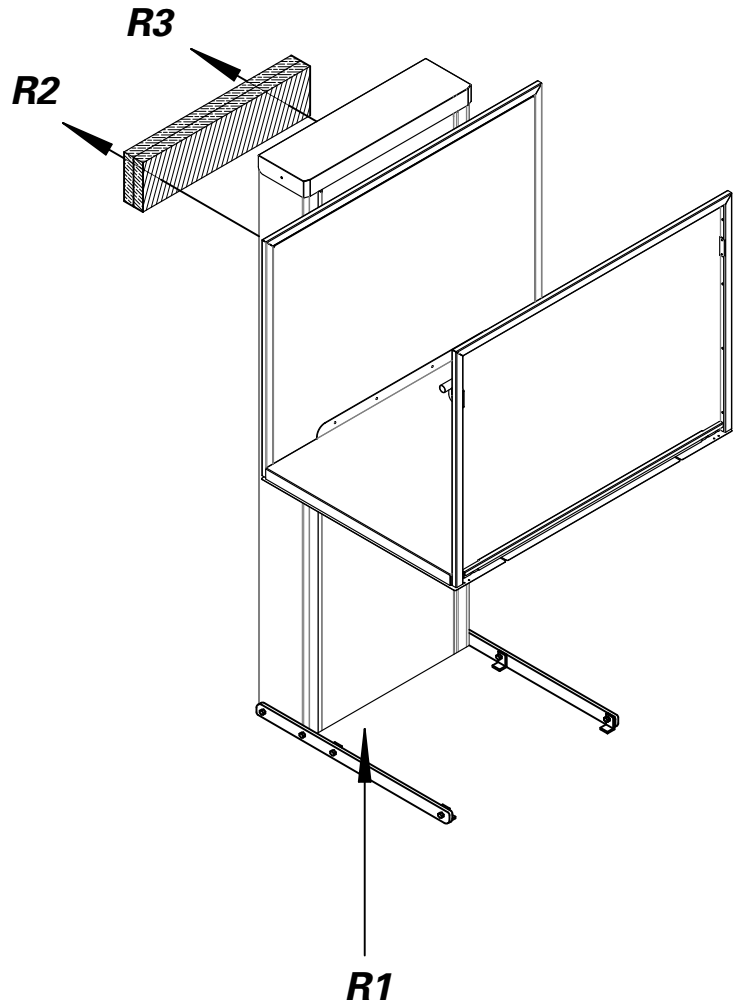

**$R1 = \text{VERTICAL FLOOR REACTION}$
(DISTRIBUTED OVER CONTACT AREA OF TOWER WITH PIT)
 $= 1600 \text{ lbf}$**

**$R2 = R3 \text{ LATERAL PULL-OUT FORCE TO RESIST}$
"TIPTING". $\text{MOMENT} = 238 \text{ lbf}$ (each fastner)**

GATES AND DOORS

Suitable for frame or masonry construction.

TO DETERMINE A DOOR OR GATE SWING: WITH THE DOOR OPEN, STAND IN THE DOORWAY WITH YOUR BACK AGAINST THE HINGES, AND MOVE YOUR ARM IN THE DIRECTION OF THE OPEN DOOR. IF YOU USE YOUR RIGHT ARM, IT IS A RIGHT HAND SWING. IF YOU USE YOUR LEFT ARM, IT IS A LEFT HAND SWING.

HOISTWAY SIDE

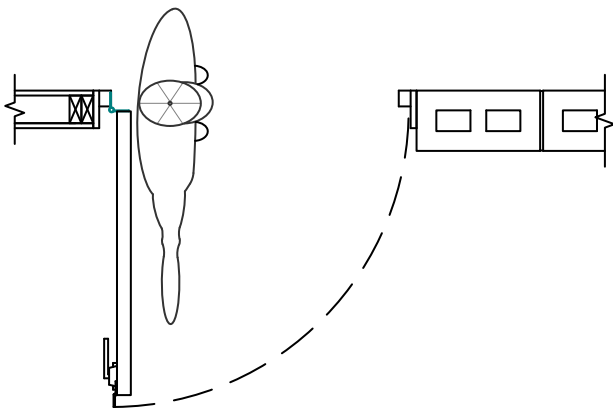

**DOOR SWING
IS
RIGHT HAND**

HOISTWAY SIDE

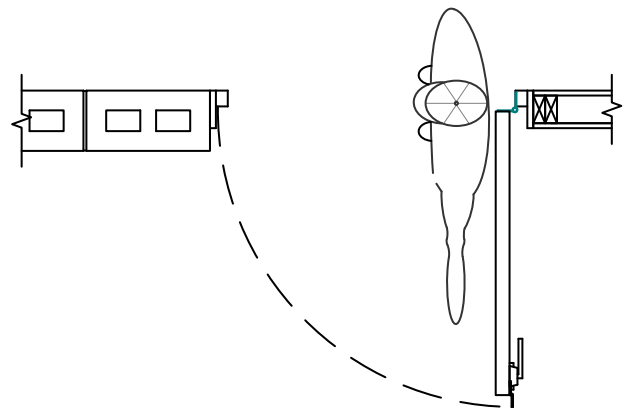

**DOOR SWING
IS
LEFT HAND**

GATES

Shown is an upper landing gate.

Upper landings are required to have a gate or door at a minimum of 42" tall and interlocked to the vertical platform lift.

In 90 degree applications, the upper landing gate is typically required to have an automatic gate/door operator.

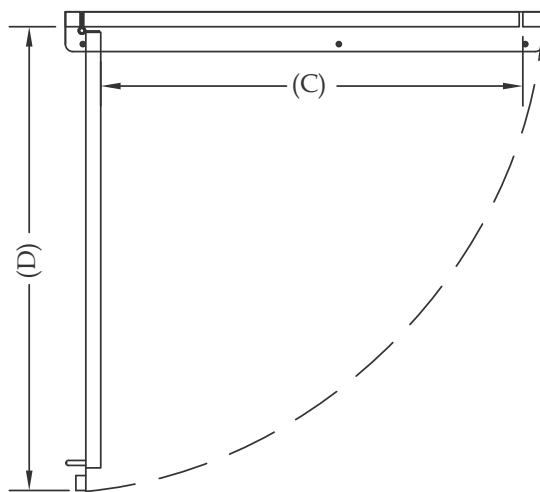
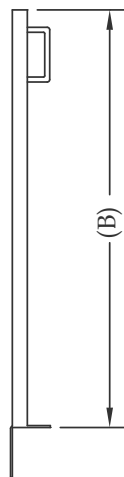
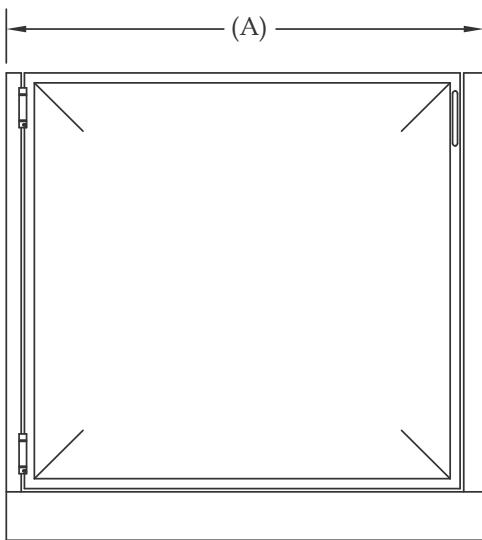
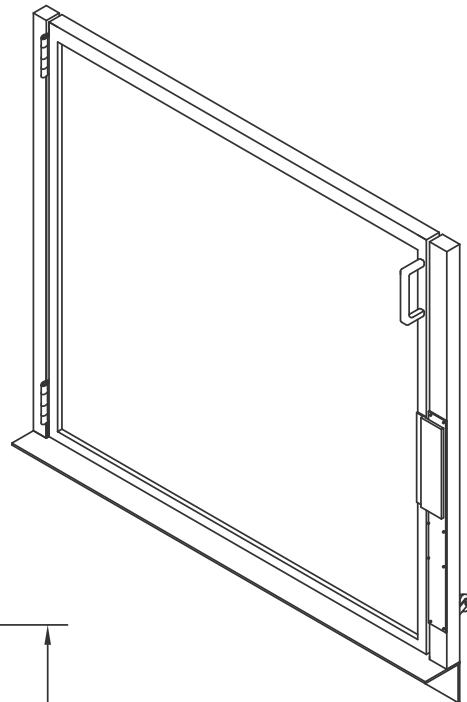

GATE INFORMATION			
(A) WIDTH	(B) HEIGHT	(C) CLEAR OPENING	(D) PROJECTION
41"	42"	35 ⁷ / ₁₆ "	39 ⁵ / ₈ "
47"	42"	41 ⁷ / ₁₆ "	45 ⁵ / ₈ "
48"	42"	42 ⁷ / ₁₆ "	46 ⁵ / ₈ "
THE GATES LISTED IN THIS CHART ARE NOT SELF SUPPORTING			

GATES

Shown is a lower landing gate.

Lower landings are required to have either a platform gate or lower landing gate or door interlocked to the vertical platform lift.

The interlock prevents the gates/door from being opened when the platform is not at the landing, as well as, preventing the vertical platform lift from moving away from a landing if the gates/doors are not closed and locked.

In 90 degree applications, the upper landing gate is typically required to have an automatic gate/door operator.

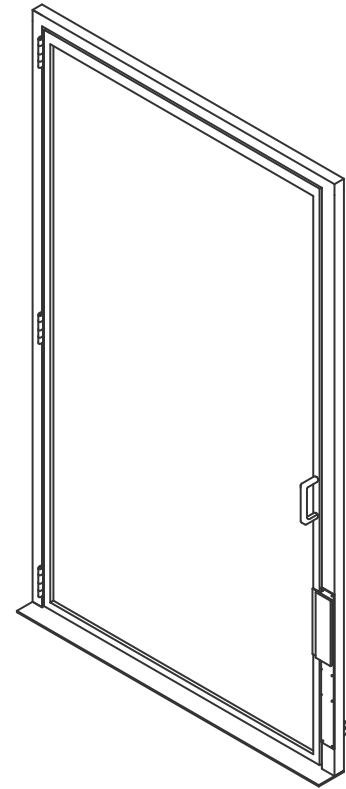

GATE INFORMATION			
(A) WIDTH	(B) HEIGHT	(C) CLEAR OPENING	(D) PROJECTION
41"	81 3/4"	35 7/16 "	39 5/8"
47"	81 3/4"	41 7/16 "	45 5/8"
48"	81 3/4"	42 7/16 "	46 5/8"
THE GATES LISTED IN THIS CHART ARE NOT SELF SUPPORTING			

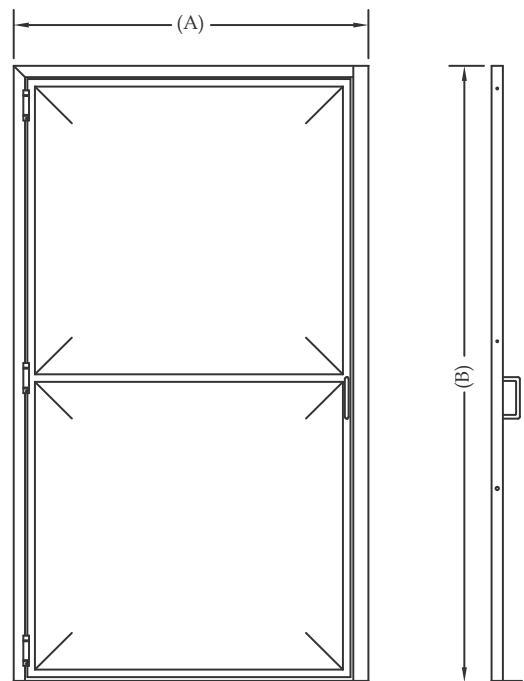
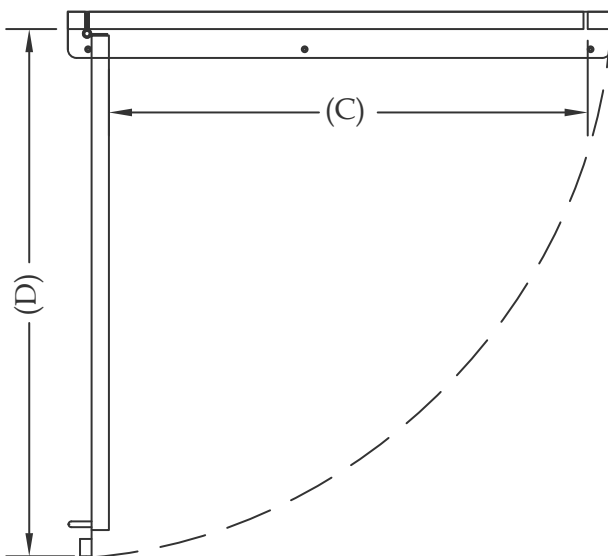

PITS & RAMPS

All applications will be installed in one of the following manners.

PIT:

For ease of use, a pit is the best option. A 3" depression in the slab is the typical pit application. This will allow for a smooth transition from the finished floor at the lowest landing to the platform surface of the vertical platform lift.

STATIONARY RAMP:

In locations where a pit is not a feasible option, a stationary ramp may be utilized. The stationary ramp is located at the lowest landing and provides access to the lift platform by transitioning from the finished floor of the lowest landing to the platform surface of the vertical platform lift.

AUTOMATIC FOLDING RAMP:

As an alternative to the pit and stationary ramp, an automatic folding ramp can be used. The automatic folding ramp is mounted to the edge of the platform on the side of the lift accessing the lowest landing. An automatic folding ramp cannot be used in a shaftway or enclosure application, nor can it be mounted on the side of the lift that is opposite the main tower. When an automatic folding ramp is used the unit must also have a safety pan.

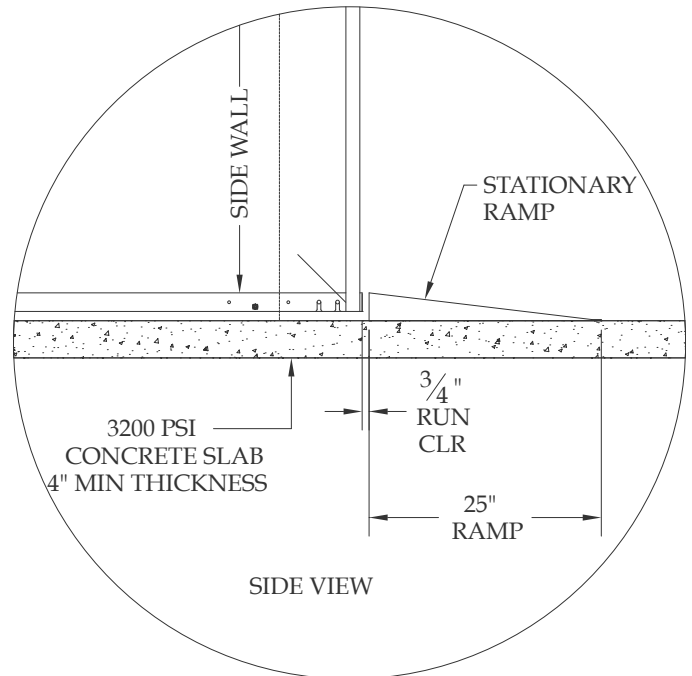

Stationary Ramp Detail

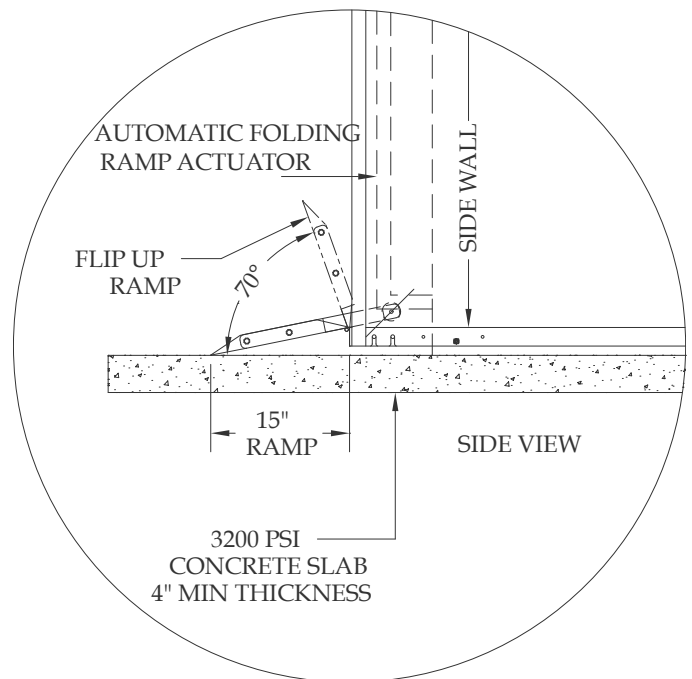

Automatic Folding Ramp Detail

CONTROLS

MAIN STATION:

A stainless steel control station is provided on the platform, consisting of an up and down directional control, illuminated emergency stop which stops the unit, and activates an alarm. An optional key switch may be added to this control.

LANDING CONTROL:

In most circumstances a control is required at all landings. The landing control is a stainless steel constant pressure call only and can be equipped with a key switch.

Landing controls can be wall mounted either on the surface or flush in the wall. Optionally, an inframe control can be added to a landing gate, provided that it is not power operated. Inframe controls cannot be used on a platform gate.

KEY-SWITCHES:

The key switch used on landing controls is the industry standard "Chicago 2252".

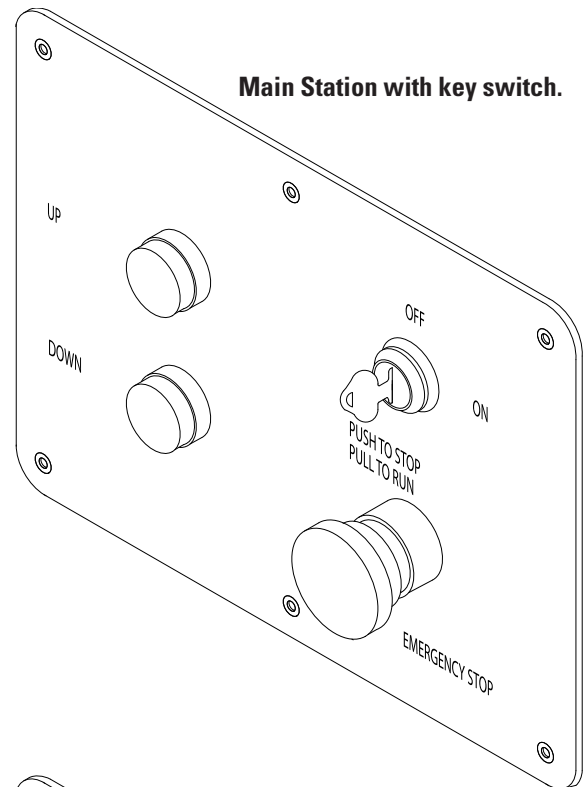

Main Station with key switch.

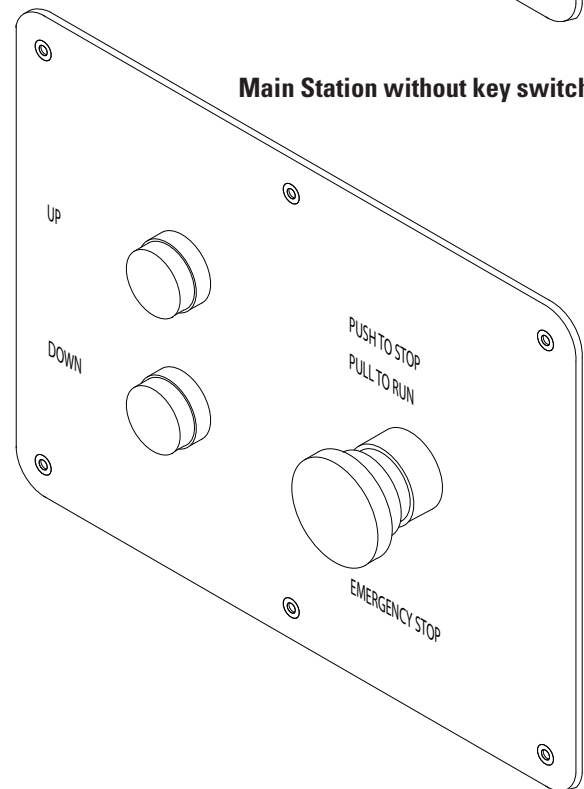

Main Station without key switch.

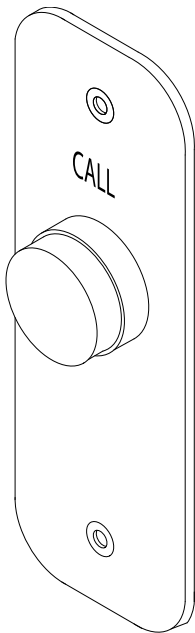

Inframe landing control without key switch.

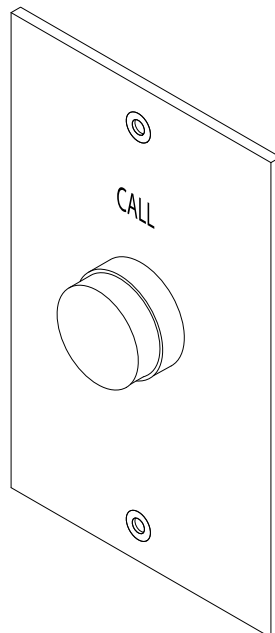

Surface or flush mount landing control without key switch.

CONSTRUCTION NOTES

- Floor to be smooth and level with 4 inch minimum concrete thickness and capable of withstanding a 3200 PSI load.
- If the conveyance is installed within a pit and is in an outdoor application, the pit must be provided with an adequate drain.
- Hoistway walls must be plumb, square, and complete to the point that it can be turned over to the customer before unit installation.
- Upper and lower doors or gates must be installed **FLUSH TO THE INTERIOR OF THE HOISTWAY.**
- 80 inch minimum head clearance is required throughout the travel of the conveyance.
- Hoistway lighting is provided by others. 5ftc required on the platform surface throughout the travel of the conveyance. An auxiliary light consisting of no fewer than 2 lamps producing .2ftc on the floor and controls for not less than 4 hours, and activated automatically in the event of a power outage.
- Main tower **MUST BE FASTENED** to the wall and floor with anchors suitable to the site conditions, and capable to withstand the forces placed upon them.
Note: If travel height is 60" or less, the wall fastening is not required.
- All blocking is provided by others.

TYPICAL CONDUIT LAYOUT

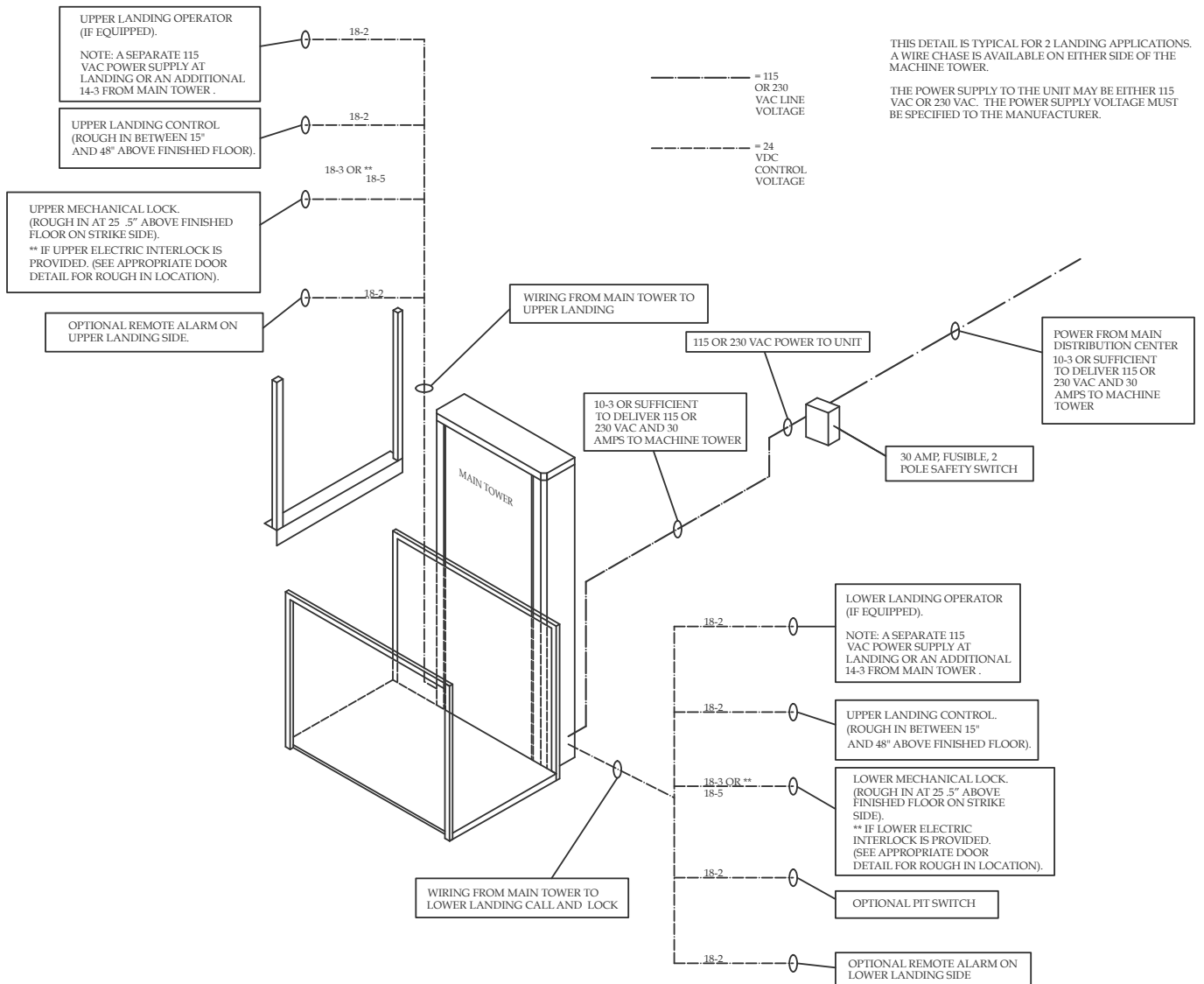

DIVISION 14 42 00 (14420)

SES Vertical Platform Lift Model VPC-UL (Unenclosed Lift) Technical Specification

PART 1 – GENERAL

1.01 SECTION INCLUDES

- A. All material and labor necessary to complete the installation of the vertical platform lift.
- B. Obtain all information affecting work at job site. Include verification of field, dimensions, anchoring and storage. Verify voltages and outlets on electrical drawings.

1.02 REFERENCES

- A. The lift shall be designed and tested in accordance with ICC/A117.1, NEC and ASME A18.1 Guidelines.
- B. All designs, clearances, construction, workmanship and installation shall be in accordance with the requirements and code adopted by the authority having jurisdiction. The platform lift shall be subject to local, city and state approval prior to and following installation.

1.03 SYSTEM DESCRIPTION

- A. The product described herein manufactured by Bella Elevator, is a Vertical Platform Lift consisting of a machine tower with lifting platform, selected and dimensioned to provide adequate lifting height to suit the individual building requirements. The lift can be used either indoors or outdoors to vertically transport a wheelchair user or mobility-impaired person up and over a barrier thus creating access to or within a building.
- B. Performance
 - 1. Rated Load : 750 pound capacity
 - 2. Travel Speed: 10fpm
 - 3. Lifting Height: up to 60" on commercial applications or up to 168" on residential applications
 - 4. Platform size: 36"x54", with non-skid surface

1.04 SUBMITTALS

- A. Submit drawings or manufactures literature for approval. Drawings shall show dimensional and wiring requirements.

1.05 QUALITY ASSURANCE

- A. Manufacture: Company shall contain personnel with not less than ten (10) years of experience in the design and fabrication of vertical platform lifts.
- B. Technical Services: Manufacture and authorized dealer shall work with architects, engineers and contractors to adapt the platform lift product to the design and structural requirements of the building, site, and code requirements.

1.06 WARRANTY

- A. Unit shall have a two (2) year limited parts warranty on the basic unit, including all electrical and drive components.

1.07 MAINTENANCE

- A. Maintenance of the platform lift unit shall consist of regular cleaning of the unit and routine safety testing at interval of not longer than every six (6) months. Rule 10.2.1 of ASME A18.1 requires all Vertical Platform Lifts be inspected every six (6) months.

PART 2 – PRODUCT

2.01 MANUFACTURE – U.S. OWNED & OPERATED

- A. Bella Elevator, as distributed by Symmetry Elevating Solutions.
- B. No Substitutions shall be considered unless written request for approval has been submitted and received by the architect at least ten (10) days prior to the bid date.

Each Substitution request shall include the name of the material for which it is to be substituted and a complete description of the proposed substitutions including drawings, performance and test data, a list of projects similar in scope, photographs of existing installation, design difference and other information necessary for evaluation

2.02 FABRICATION

- A. Platform shall be constructed of 12-gauge minimum hot rolled steel. If unit is not installed in a 3-inch pit, an auto-retracting ramp shall be provided that extends to meet lower landing.
- B. Platform side panels must be 42" high. Side panel framework shall be a minimum of 1" x 1 1/2" steel. Solid infill panels shall be a minimum of 18 gauge Steel.
- C. The Mainframe (Main Tower) support shall be a combination 7 gauge C Channel, 7 gauge interface plates and 16 gauge exterior skin.
- D. Carriage platform supports shall be a minimum of 1/2" steel plate and carriage uprights shall be a minimum of 3/8" thick laser cut steel plate.
- E. Elevator style (Nylon) rollers shall be used for axial carriage guidance and wear pads shall be used for horizontal stability.
- F. Loaded fasteners shall be grade eight or higher. Locking fasteners shall be used in all critical locations.
- G. The drive mechanism shall be a stationary nut on a rotating 1" diameter Acme screw with a secondary safety nut.
- H. The motor shall be 1 HP, 115 volt, 1 phase.
- I. The operating control circuit shall be a regulated N.R.T.L. listed class 2 power limited circuit operating at 24vdc.
- J. On board Diagnostics with LED indicators.
- K. Unit can be fitted with optional remote mounted controller (See Accessories)
- L. Finish shall be electro statically applied powder coating, oven baked to cure.
- M. Color shall be selected from manufactures standard ivory color or optional colors of white, gray or black.

DIVISION 14 42 00 (14420)

SES Vertical Platform Lift Model VPC-UL (Unenclosed Lift) Technical Specification (Continued)

- N. An upper final limit switch shall be provided.
- O. A constant pressure up/down control switch shall be installed on the platform.
- P. A constant pressure, elevator style, hall call control switch shall be provided at each landing.
- Q. When not installed with a runway enclosure, the platform shall be equipped with an obstruction panel that will stop only the downward travel if an obstruction is encountered.
- R. An illuminated emergency stop switch / Audible alarm switch shall be provided on the car as a means of signaling for assistance in the event of an emergency.
- S. A grab rail shall be provided on the platform.
- T. A gate with a min. height of 42" and a combination mechanical lock with an electric contact shall be provided at the upper landing.
- U. A gate with a combination mechanical lock with an electric contact shall be provided at the lower level. The type and height shall depend on model and code requirements.
- V. Unit to be equipped with the "articulating" base and carriage design, which allows the carriage to be folded to reduce the tower and carriage width to 21", for ease of installation, without removal of the carriage.
- W. Unit must be assembled and tested in factory before shipment.

2.03 ACCESSORIES

SPECIFIER PLEASE NOTE – Due to different applications of Vertical Platform Lifts, please strike the optional items shown if not used.

- A. A CSD-Rated (R) Fire Rated (B Label) flush mounted steel door and frame shall be provided. Door shall include wire mesh vision panel with delay action door closure, dead latch, dummy trim door handle and electric strike. (If used at upper landing, delete 2.02 T. If used at lower landing, delete 2.02 U.)
- B. A CSD – Non-Rated (NR) Low profile flush mounted steel door and frame shall be provided. Door shall include mesh vision panel with delay action door closure, dead latch, dummy trim door handle, lock plate cover and electric strike.
- C. A CWD – Flush mounted, solid core oak laminated door and (oak) frame shall be provided. Door shall include mesh vision panel with delay action door closure, dead latch, dummy trim door handle, lock plate cover and electric strike. (If used at upper landing, delete 2.02 T. If used at lower landing, delete 2.02 U.)
- D. Flush mounted, 42 inches high, solid core oak laminated gate and (oak) frame shall be provided at the upper landing. Gate includes spring hinges, dead latch, dummy trim gate handle, lock plate cover and electric strike. (If used, delete 2.02 T)

- E. A 24V DC, fail secure electric strike that contains electric contacts to insure the door is both closed and locked shall be provided. (This option is required when flush mounted door frames are provided by others. Modify or delete 2.02 T and/or 2.02 U.)
- F. Optional platform configuration; 90 degree; other platforms are available 36"x48", 36"x60", 42"x60" (Modify or delete 1.03 B4.)
- G. Low power door operator – 115v, 15A, low energy, ADA compliant processor controlled, and fully adjustable operator.
- H. Mid mount gate operator
- I. An optional lowering device must be provided as a means of manually raising and lowering the platform.
- J. Remote mounted controller allows for readily serviceable diagnostics at upper or lower landing.
- K. Optional Battery Back-Up shall automatically operate the lift during facility power failure using a 12VDC Battery Back-Up System.

PART 3 – EXECUTION

3.01 ACCEPTABLE INSTALLERS

- A. Subcontractor Qualifications: A company that is listed as a authorized Symmetry Elevating Solutions dealer. See www.symmetryelevator.com for details.
- B. Electrical devices, service and final connections shall be by a qualified electrician.

3.02 INSTALLATION

- A. Unit shall be installed and operated in accordance with the ICC/A117.1, NEC and ASME A18.1 Guidelines.
- B. A lockable service disconnect switch rated at 110v 30A shall be supplied by the electrical contractor at job site.
- C. A dedicated electrical supply provided to the disconnect shall be capable of supplying 30A, at 115v at disconnecting means.
- D. GC to coordinate "work by others" with lift contractor.
- E. The installation of the vertical platform lift shall be made in accordance with approved plans and specifications and the manufactures installation instructions.

3.03 FIELD QUALITY CONTROL

- A. Load the vertical lift to rated capacity and test for several cycles to insure proper operation. No mechanical failures shall occur and no wear that would affect the reliability of the unit shall be detected.

**FOR MORE DETAILS:
CALL SYMMETRY ELEVATING SOLUTIONS**

DIVISION 14 42 00 (14420)

SES Vertical Platform Lift Model VPC-SL (Shaftway Lift) All Styles

PART 1 – GENERAL

1.01 SECTION INCLUDES

- A. All material and labor necessary to complete the installation of the vertical platform lift.
- B. Obtain all information affecting work at job site. Include verification of field, dimensions, anchoring and storage. Verify voltages and outlets on electrical drawings.

1.02 REFERENCES

- A. The lift shall be designed and tested in accordance with ICC/A117.1, NEC and ASME A18.1 Guidelines.
- B. All designs, clearances, construction, workmanship and installation shall be in accordance with the requirements and code adopted by the authority having jurisdiction. The platform lift shall be subject to local, city and state approval prior to and following installation.

1.03 SYSTEM DESCRIPTION

- A. The product described herein manufactured by Bella Elevator, is a Vertical Platform Lift consisting of a machine tower with lifting platform, selected and dimensioned to provide adequate lifting height to suit the individual building requirements. The lift can be used either indoors or outdoors to vertically transport a wheelchair user or mobility-impaired person up and over a barrier thus creating access to or within a building.
- B. Performance
 - 1. Rated Load : 750 pound capacity
 - 2. Travel Speed: 10fpm
 - 3. Lifting Height: From 42" to 168"
 - 4. Platform size: 36"x54", with non-skid surface

1.04 SUBMITTALS

- A. Submit drawings or manufactures literature for approval. Drawings shall show dimensional and wiring requirements.

1.05 QUALITY ASSURANCE

- A. Manufacture: Company shall contain personnel with not less than ten (10) years of experience in the design and fabrication of vertical platform lifts.
- B. Technical Services: Manufacture and authorized dealer shall work with architects, engineers and contractors to adapt the platform lift product to the design and structural requirements of the building, site, and code requirements.

1.06 WARRANTY

- A. Unit shall have a two (2) year limited parts warranty on the basic unit, including all electrical and drive components.

1.07 MAINTENANCE

- A. Maintenance of the platform lift unit shall consist of regular cleaning of the unit and routine safety testing at interval of not longer than every six (6) months. Rule 10.2.1 of ASME A18.1 requires all Vertical Platform Lifts be inspected every six (6) months.

PART 2 – PRODUCT

2.01 MANUFACTURE – U.S. OWNED & OPERATED

- A. Bella Elevator, as distributed by Symmetry Elevating Solutions.
- B. No Substitutions shall be considered unless written request for approval has been submitted and received by the architect at least ten (10) days prior to the bid date.

Each Substitution request shall include the name of the material for which it is to be substituted and a complete description of the proposed substitutions including drawings, performance and test data, a list of projects similar in scope, photographs of existing installation, design difference and other information necessary for evaluation

2.02 FABRICATION

- A. Platform shall be constructed of 12-gauge minimum hot rolled steel. If unit is not installed in a 3-inch pit, an auto-retracting ramp shall be provided that extends to meet lower landing.
- B. Platform side panels must be 42" high. Side panel framework shall be a minimum of 1" x 1 ½" steel. Solid infill panels shall be a minimum of 18 gauge Steel.
- C. The Mainframe (Main Tower) support shall be a combination 7 gauge C Channel, 7 gauge interface plates and 16 gauge exterior skin.
- D. Carriage platform supports shall be a minimum of ½" steel plate and carriage uprights shall be a minimum of 3/8" thick laser cut steel plate.
- E. Elevator style (Nylon) rollers shall be used for axial carriage guidance and wear pads shall be used for horizontal stability.
- F. Loaded fasteners shall be grade eight or higher. Locking fasteners shall be used in all critical locations.
- G. The drive mechanism shall be a stationary nut on a rotating 1" diameter Acme screw with a secondary safety nut.
- H. The motor shall be 1 HP, 115 volt, 1 phase.
- I. The operating control circuit shall be a regulated N.R.T.L. listed class 2 power limited circuit operating at 24vdc.
- J. On board Diagnostics with LED indicators.
- K. Unit can be fitted with optional remote mounted controller (See Accessories)
- L. Finish shall be electro statically applied powder coating, oven baked to cure.
- M. Color shall be selected from manufactures standard Ivory color or optional colors of white, gray, or black.
- N. An upper final limit switch shall be provided.

DIVISION 14 42 00 (14420)

SES Vertical Platform Lift Model VPC-SL (Shaftway Lift) - All Styles (Continued)

- O. A constant pressure up/down control switch shall be installed on the platform.
- P. A constant pressure, elevator style, hall call control switch shall be provided at each landing.
- Q. When not installed with a runway enclosure, the platform shall be equipped with an obstruction panel that will stop only the downward travel if an obstruction is encountered.
- R. An illuminated emergency stop switch / Audible alarm switch shall be provided on the car as a means of signaling for assistance in the event of an emergency.
- S. A grab rail shall be provided on the platform.
- T. A gate with a min. height of 42" and a combination mechanical lock with an electric contact shall be provided at the upper landing.
- U. A gate with a combination mechanical lock with an electric contact shall be provided at the lower level. The type and height shall depend on model and code requirements.
- V. Unit to be equipped with the "articulating" base and carriage design, which allows the carriage to be folded to reduce the tower and carriage width to 21", for ease of installation, without removal of the carriage.
- W. Unit must be assembled and tested in factory before shipment.

2.03 ACCESSORIES

SPECIFIER PLEASE NOTE – Due to different applications of Vertical Platform Lifts, please strike the optional items shown if not used.

- A. A CSD-Rated (R) Fire Rated (B Label) flush mounted steel door and frame shall be provided. Door shall include wire mesh vision panel with delay action door closure, dead latch, dummy trim door handle and electric strike. (If used at upper landing, delete 2.02 T. If used at lower landing, delete 2.02 U.)
- B. A CSD – Non-Rated (NR) Low profile flush mounted steel door and frame shall be provided. Door shall include mesh vision panel with delay action door closure, dead latch, dummy trim door handle, lock plate cover and electric strike.
- C. A CWD – Flush mounted, solid core oak laminated door and (oak) frame shall be provided. Door shall include mesh vision panel with delay action door closure, dead latch, dummy trim door handle, lock plate cover and electric strike. (If used at upper landing, delete 2.02 T. If used at lower landing, delete 2.02 U.)
- D. Flush mounted, 42 inches high, solid core oak laminated gate and (oak) frame shall be provided at the upper landing. Gate includes spring hinges, dead latch, dummy trim gate handle, lock plate cover and electric strike. (If used, delete 2.02 T)
- E. A 24V DC, fail secure electric strike that contains electric contacts to insure the door is both closed and locked shall be provided. (This option is required when flush mounted door frames are provided by others. Modify or

- delete 2.02 T and/or 2.02 U.)
- F. Optional platform configuration; 90 degree; other platforms are available 36"x48", 36"x60", 42"x60" (Modify or delete 1.03 B4.)
- G. Low power door operator – 115v, 15A, low energy, ADA compliant processor controlled, and fully adjustable operator.
- H. Mid mount gate operator
- I. An optional lowering device must be provided as a means of manually raising and lowering the platform.
- J. Remote mounted controller allows for readily serviceable diagnostics at upper or lower landing.
- K. Optional Battery Back-Up shall automatically operate the lift during facility power failure using a 12VDC Battery Back-Up System.

3.01 ACCEPTABLE INSTALLERS

- A. Subcontractor Qualifications: A company that is listed as a authorized Symmetry Elevating Solutions dealer. See www.symmetryelevator.com for details.
- B. Electrical devices, service and final connections shall be by a qualified electrician.

3.02 INSTALLATION

- A. Unit shall be installed and operated in accordance with the ICC/A117.1, NEC and ASME A18.1 Guidelines.
- B. A lockable service disconnect switch rated at 110v 30A shall be supplied by the electrical contractor at job site.
- C. A dedicated electrical supply provided to the disconnect shall be capable of supplying 30A, at 115v at disconnecting means.
- D. GC to coordinate "work by others" with lift contractor.
- E. The installation of the vertical platform lift shall be made in accordance with approved plans and specifications and the manufactures installation instructions.

3.03 FIELD QUALITY CONTROL

- A. Load the vertical lift to rated capacity and test for several cycles to insure proper operation. No mechanical failures shall occur and no wear that would affect the reliability of the unit shall be detected.

**For more details, call Symmetry Elevating Solutions
Design Line 866-968-5438**

DIVISION 14 42 00 (14420)

SES Vertical Platform Lift Model VPC-EL (Enclosure Lift) - All Styles

PART 1 – GENERAL

1.01 SECTION INCLUDES

- A. All material and labor necessary to complete the installation of the vertical platform lift.
- B. Obtain all information affecting work at job site. Include verification of field, dimensions, anchoring and storage. Verify voltages and outlets on electrical drawings.

1.02 REFERENCES

- A. The lift shall be designed and tested in accordance with ICC/A117.1, NEC and ASME A18.1 Guidelines.
- B. All designs, clearances, construction, workmanship and installation shall be in accordance with the requirements and code adopted by the authority having jurisdiction. The platform lift shall be subject to local, city and state approval prior to and following installation.

1.03 SYSTEM DESCRIPTION

- A. The product described herein manufactured by Bella Elevator, is a Vertical Platform Lift consisting of a machine tower with lifting platform, selected and dimensioned to provide adequate lifting height to suit the individual building requirements. The lift can be used either indoors or outdoors to vertically transport a wheelchair user or mobility-impaired person up and over a barrier thus creating access to or within a building.
- B. Performance
 - 1. Rated Load : 750 pound capacity
 - 2. Travel Speed: 10fpm
 - 3. Lifting Height: From 42" to 168".
 - 4. Platform size: 36"x54", with non-skid surface

1.04 SUBMITTALS

- A. Submit drawings or manufactures literature for approval. Drawings shall show dimensional and wiring requirements.

1.05 QUALITY ASSURANCE

- A. Manufacture: Company shall contain personnel with not less than ten (10) years of experience in the design and fabrication of vertical platform lifts.
- B. Technical Services: Manufacture and authorized dealer shall work with architects, engineers and contractors to adapt the platform lift product to the design and structural requirements of the building, site, and code requirements.

1.06 WARRANTY

- A. Unit shall have a two (2) year limited parts warranty on the basic unit, including all electrical and drive components.

1.07 MAINTENANCE

- A. Maintenance of the platform lift unit shall consist of regular cleaning of the unit and routine safety testing at interval of not longer than every six (6) months. Rule 10.2.1 of ASME A18.1 requires all Vertical Platform Lifts be inspected every six (6) months.

PART 2 – PRODUCT

2.01 MANUFACTURE – U.S. OWNED & OPERATED

- A. Bella Elevator, as distributed by Symmetry Elevating Solutions.
- B. No Substitutions shall be considered unless written request for approval has been submitted and received by the architect at least ten (10) days prior to the bid date.

Each Substitution request shall include the name of the material for which it is to be substituted and a complete description of the proposed substitutions including drawings, performance and test data, a list of projects similar in scope, photographs of existing installation, design difference and other information necessary for evaluation

2.02 FABRICATION

- A. Platform shall be constructed of 12-gauge minimum hot rolled steel. If unit is not installed in a 3-inch pit, an auto-retracting ramp shall be provided that extends to meet lower landing.
- B. Platform side panels must be 42" high. Side panel framework shall be a minimum of 1" x 1 ½" steel. Solid infill panels shall be a minimum of 18 gauge Steel.
- C. The Mainframe (Main Tower) support shall be a combination 7 gauge C Channel, 7 gauge interface plates and 16 gauge exterior skin.
- D. Carriage platform supports shall be a minimum of ½" steel plate and carriage uprights shall be a minimum of 3/8" thick laser cut steel plate.
- E. Elevator style (Nylon) rollers shall be used for axial carriage guidance and wear pads shall be used for horizontal stability.
- F. Loaded fasteners shall be grade eight or higher. Locking fasteners shall be used in all critical locations.
- G. The drive mechanism shall be a stationary nut on a rotating 1" diameter Acme screw with a secondary safety nut.
- H. The motor shall be 1 HP, 115 volt, 1 phase.
- I. The operating control circuit shall be a regulated N.R.T.L. listed class 2 power limited circuit operating at 24vdc.
- J. On board Diagnostics with LED indicators.
- K. Unit can be fitted with optional remote mounted controller (See Accessories)
- L. Finish shall be electro statically applied powder coating, oven baked to cure.
- M. Color shall be selected from manufactures standard ivory color or optional colors of white, gray, or black.
- N. An upper final limit switch shall be provided.
- O. A constant pressure up/down control switch shall be installed on the platform.
- P. A constant pressure, elevator style, hall call control switch shall be provided at each landing.
- Q. When not installed with a runway enclosure, the platform shall be equipped with an obstruction panel that will stop only the downward travel if an obstruction is encountered.
- R. An illuminated emergency stop switch / Audible alarm switch shall be provided on the car as a means of signaling for assistance in the event of an emergency.

DIVISION 14 42 00 (14420)

SES Vertical Platform Lift Model VPC-EL (Enclosure Lift) - All Styles (Continued)

S. A grab rail shall be provided on the platform.
 T. Lift shall have an enclosure framework of 1½" square steel tubing for indoor and outdoor units; outdoor units will have a military grade primer along with standard powder coat paint finish. Unit shall have enclosure panels of 18-gauge galvanealed or galvanized steel, minimum or Acrylic Panels in either clear or smoked finishes. Three styles of enclosures are available.

a. The enclosure shall extend a minimum of six (6) inches above the actual lifting height of the unit (Platform gate required), which prevents access to the underside of the platform.

i. Lift shall be equipped with a 42" minimum high upper landing gate, 42" high platform gate which rides on the platform and a lower landing gate which remains at lower level to prevent access to the underside of the platform while in the raised position.

b. The enclosure shall extend a minimum of forty two (42) inches above the actual lifting height of the unit, which prevents access to the underside of the platform.

i. The platform gate may / will be eliminated if the entire enclosure and lower gate extends a minimum 42" above the lift height.

c. The enclosure shall extend a minimum of six foot eight (6'8") inches above the actual lifting height of the unit, which prevents access to the underside of the platform.

i. Lift shall be equipped with an 80" minimum high upper landing door /gate and a lower landing door/gate which remains at lower level to prevent access to the underside of the platform while in the raised position.

U. A gate with a min. height of 42" and a combination mechanical lock with an electric contact shall be provided at the upper landing.

V. A gate with a combination mechanical lock with an electric contact shall be provided at the lower level. The type and height shall depend on model and code requirements.

W. Unit to be equipped with the "articulating" base and carriage design, which allows the carriage to be folded to reduce the tower and carriage width to 21", for ease of installation, without removal of the carriage.

X. Unit must be assembled and tested in factory before shipment.

2.03 ACCESSORIES

SPECIFIER PLEASE NOTE – Due to different applications of Vertical Platform Lifts, please strike the optional items shown if not used.

A. A CSD-Rated (R) Fire Rated (B Label) flush mounted steel door and frame shall be provided. Door shall include wire mesh vision panel with delay action door closure, dead latch, dummy trim door handle and electric strike. (If used at upper landing, delete 2.02 T. If used at lower landing, delete 2.02 U.)

B. A CSD – Non-Rated (NR) Low profile flush mounted steel door and frame shall be provided. Door shall include mesh vision panel with delay action door closure, dead latch, dummy trim door handle, lock plate cover and electric strike.

C. A CWD – Flush mounted, solid core oak laminated door and (oak) frame shall be provided. Door shall in-

clude mesh vision panel with delay action door closure, dead latch, dummy trim door handle, lock plate cover and electric strike. (If used at upper landing, delete 2.02 T. If used at lower landing, delete 2.02 U.)

D. Flush mounted, 42 inches high, solid core oak laminated gate and (oak) frame shall be provided at the upper landing. Gate includes spring hinges, dead latch, dummy trim gate handle, lock plate cover and electric strike. (If used, delete 2.02 T)

E. A 24V DC, fail secure electric strike that contains electric contacts to insure the door is both closed and locked shall be provided. (This option is required when flush mounted door frames are provided by others. Modify or delete 2.02 T and/or 2.02 U.)

F. Optional platform configuration; 90 degree; other platforms are available 36"x48", 36"x60", 42"x60" (Modify or delete 1.03 B4.)

G. Low power door operator-115v, 15A, low energy. ADA compliant processor controlled and fully adjustable operator.

H. Mid mount gate operator

I. An optional lowering device must be provided as a means of manually raising and lowering the platform.

J. Remote mounted controller allows for readily serviceable diagnostics at upper or lower landing.

K. Optional Battery Back-Up shall automatically operate the lift during facility power failure using a 12VDC Battery Back-Up System.

PART 3 – EXECUTION

3.01 ACCEPTABLE INSTALLERS

A. Subcontractor Qualifications: A company that is listed as a authorized Symmetry Elevating Solutions dealer. See www.symmetryelevator.com for details.

B. Electrical devices, service and final connections shall be by a qualified electrician.

3.02 INSTALLATION

A. Unit shall be installed and operated in accordance with the ICC/A117.1, NEC and ASME A18.1 Guidelines.

B. A lockable service disconnect switch rated at 110v 30A shall be supplied by the electrical contractor at job site.

C. A dedicated electrical supply provided to the disconnect shall be capable of supplying 30A, at 115v at disconnecting means.

D. GC to coordinate "work by others" with lift contractor.

E. The installation of the vertical platform lift shall be made in accordance with approved plans and specifications and the manufactures installation instructions.

3.03 FIELD QUALITY CONTROL

A. Load the vertical lift to rated capacity and test for several cycles to insure proper operation. No mechanical failures shall occur and no wear that would affect the reliability of the unit shall be detected.

For more details, call Symmetry Elevating Solutions Design Line 866-968-5438



VERTICAL PLATFORM LIFTS

Symmetry Elevating Solutions
8915 North Pioneer Road, Suite A
Peoria, IL 61615
866.785.6203

www.SymmetryElevator.com