

NEW



SERIES B "BOX-LIFT" PROVIDES SAFE AND CONVENIENT TRANSPORTATION BETWEEN LEVELS FOR SMALL LOADS AND PACKAGES WITH VERY LOW "LIFE-CYCLE" COST.

- Ideal for lifting boxes, totes, cartons, barrels, sacks, cases, individual parts or miscellaneous items. Moves loads to mezzanines, between floors or between conveyor levels.
- Completely self-contained, self-supporting and economical to own. Durable, high quality construction ensures safe, reliable long-term performance.
- Capacity of 300 or 500 lbs. with 3' x 3' carriage. Travel speeds of 40 fpm.
- Mechanical motor/gear reducer with frequency drive provides soft start and soft stop. Carriage decelerates to stop position which extends brake life.
- Modular design for easy installation and minimal maintenance.
- Unit ships pre-assembled and pre-wired with "quick-connect" wiring.
- Allows loading and unloading from three sides at each level.
- Access gates are provided at each level and interlocked with lift operation. Gates are modular and can be configured to hinge right and lock left or hinge left and lock right.
- Built-in, advanced safety features protect workers and materials.
- Unlike similar lifts in the industry Series B Lift is ASME B20.1 Code compliant.

➤ **FAST DELIVERY:**
SHIPPED 3 WEEKS AFTER ORDER!

For immediate answers to your application questions, Call Pflow at 414-352-9000, or visit: www.pflow.com

SERIES B

DIMENSIONS & DATA

LIFT PLAN VIEW

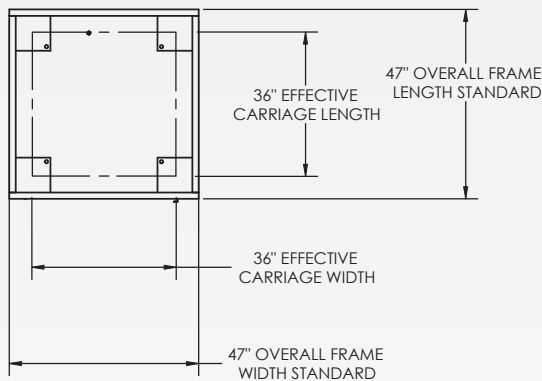

LIFT FRONT VIEW

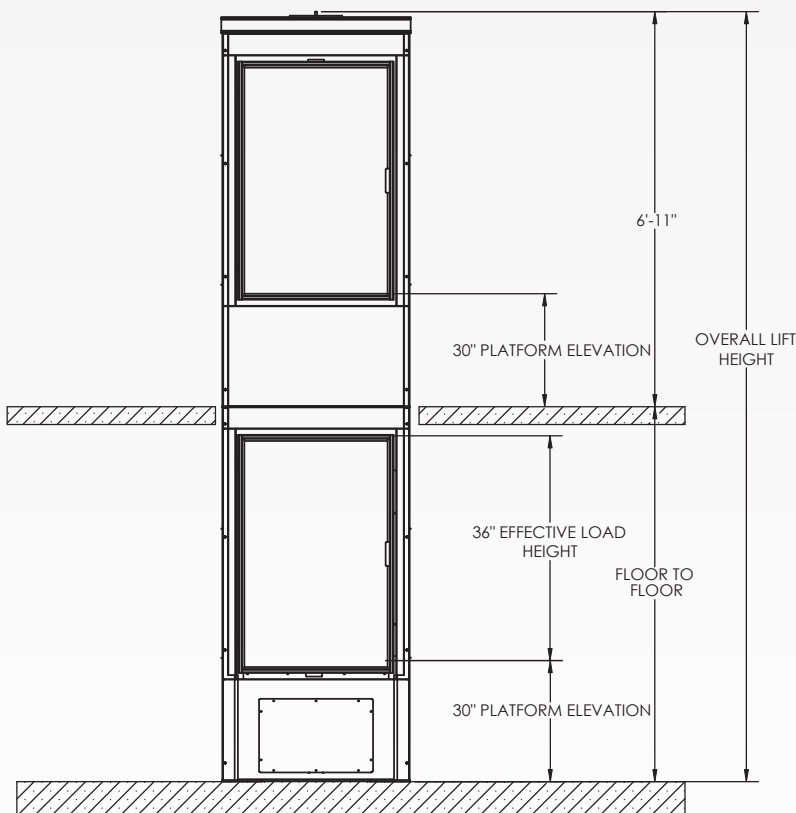

Note: The dimensions shown are illustrative. Request a job-specific drawing before making any building modifications.

SPECIFICATIONS

GENERAL

Pflow Series B Vertical Lift offers simple and convenient transportation of materials between two or more levels. Principle components include modular steel enclosure, mechanical drive assembly, and lift carriage.

APPLICATION DATA

Series B lifts are available with: Live load lifting capacities of 300 or 500 lbs.; carriage size of 3' x 3'. Standard travel speed is 40 fpm.

STRUCTURE

Stackable modular formed steel panels provide full height guarding and internal guide for carriage assembly. Gate arrangement can be easily changed for right hand or left hand swing open pattern.

OPERATION

Carriage is lifted and lowered by dual roller chains connected to electric motor-reducer assembly. Motor-reducer assembly is mounted within lift enclosure at floor level with easy access door for maintenance.

ELECTRICAL

Standard power requirements are 230V single-phase or 230V/460V 3-phase. Low voltage controls. NEMA 12 rated momentary contact push button stations are provided for each level and include call/send and E-stop. Quick-connect wiring is provided and ships partially pre-wired to speed installation.

SAFETY FEATURES

Pflow Series B Lift is the safest modular small package lift on the market and is ASME B20.1 Code compliant. Features include exclusive spring loaded dual safety pins that prevent uncontrolled descent in case of chain break; elevator approved electro-mechanical door interlocks; full height safety enclosures; overload protection.

APPLICATIONS INCLUDE

- Auto Dealership Parts Rooms
- Retail Back Rooms
- Mezzanines
- Liquor Stores
- Shoe Stores
- Libraries
- Office Store Rooms
- Restaurants
- Tool Crib Storage
- Warehousing